

Varenummer: 2301044221
 Beskrivelse: E+G Håndsving
 MT.80+IR-A10

Mål

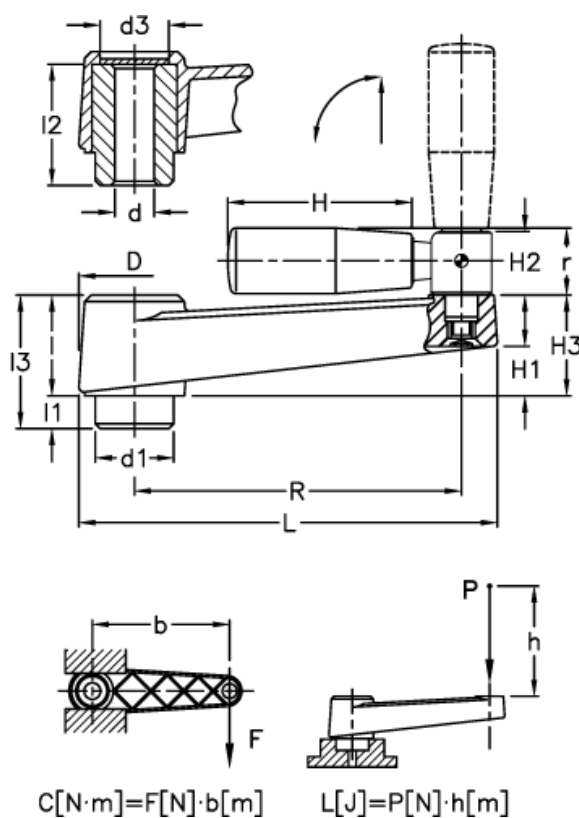

C (N*m) = 180	H3 = 27	R = 80
D = 30	l = 26	
d1 = 22	L = 105	
d3 = 17	L (J) = 15	
d H7 = 10	l1 = 10	
H = 56	l2 = 32	
H1 = 13	l3 = 36	
H2 = 15	r = 19	